



BELLE
LIGHT
CONSTRUCTION
EQUIPMENT



DX 1000 HT

1-TONNE HI-TIP DUMPER



BELLE
LIGHT
CONSTRUCTION
EQUIPMENT

DX 1000 1-TONNE HI-TIP DUMPER

A DIAMOND IN THE ROUGH!!

The **BRAND NEW** DX 1000HT is the new No1. Best in Class 1-tonne high-tip dumper. Designed to be owned by a rental company or professional operator.

The DX 1000HT sets new standards for safety, strength, operator comfort and convenience and productivity on site. With a proven, reliable Yanmar 3TNV76, 3 cylinder, Diesel engine - perfect for this application.

FEATURES & BENEFITS

Operator Comfort and Convenience

- Fuel level is visible while in the operator's seat, saving time & improving safety & down time.
- Increased leg room for improved operator comfort.
- USB phone charger point, allowing charging while the work is done.
- Leading brand, comfort seat compliant to latest standards EN ISO 7096 for this type of equipment. Reduces operator fatigue, improves operator experience.

Strength

- Robust, easy-clean skip with fully returned edges preventing dirt ingress / concrete accumulation, reducing down time and cleaning costs.
- Strengthened chassis rails to increase durability.
- High quality, shot-blast and 2-layer powder coated paint finish for the most demanding site conditions. Maximising resale values.
- Bushed & greased steering pivot cylinder, preventing wear on the main components, cost efficient for the owners.
- Steel belly pan protector prevents damage to hydraulic circuit.
- Front enclosure / infill plate reduces stone / mud ingress meaning less down time & cleaning required.
- Steering Ram - Hose guard cover plate to prevent damage.
- Hi-quality leading brand all-terrain tyres fitted with valve protect guard, to reduce down time on site and increase productivity.



HIGH-QUALITY, ALL-TERRAIN TYRES WITH VALVE PROTECT GUARD & WHEEL NUT INDICATORS



ROBUST, EASY-CLEAN 1000KG CAPACITY SKIP FULLY RETURNED EDGES TO PREVENT DIRT INGRESS

Productivity

- The Altrad full 4 wheel drive system hydraulic system gives increased traction on poor terrain and excessive mud. Better gradeability, increased productivity and less servicing.
- Reliable, Yanmar 3TNV76 Diesel engine - perfect for this application.
- Market leading fuel tank capacity, reduces amount of fill-ups and down time.
- Unique fuel level indicator window together with a low fuel level warning light allows for easy inspection and assist in ensuring rental & machine productivity high.
- Low hydraulic fluid level warning light reducing system damage and down time.
- Extensive use of hose clamp retainers to prevent pipe fretting and rubbing, reducing hose failures and maintenance costs.
- Fuel and Hydraulic tank drain points reducing tank flushing time in the event of contamination or servicing.
- Fuel - water separator reducing engine damage and down time.
- Central Hydraulic hoses enables increased protection, reducing the risk of down time.
- Under footplate - stone guards preventing stone/mud ingress, so less down time & cleaning required.



Safety

- Tight turning circle allows better manoeuvrability on tight work sites, reducing shunting and increasing safety, productivity & efficiency.
- High viz access points & anti-slip foot-steps reduces slips, trips and falls when climbing on and off machine. Easily replaceable in case of an impact.
- Auto retracting seat belt prevents entanglement. Bright Orange for safety with increased visibility.
- Safe heavy duty, easy to deploy steering lock out bar, makes workshop and transport actives safer.
- "Check Point" visual wheel nut indicators make daily checks simpler to perform, reducing machine down time.
- Enclosed document box to retain machine safety documents reducing possibility of being damaged / misplaced.
- Lockable seat pan - gas strut c/w lock out reduces chance of head / trapping injuries.
- Anti-slip, hot-dipped galvanised floor plate for safety and long life.
- Hazard warning chevron's on rear of dumper for increased machine visibility on site to others.
- Priority / safety steering valve that gives priority to the steer function in the event of low hydraulic fluid pressure or flow, therefore maintain-highest levels of machine safety at all times.

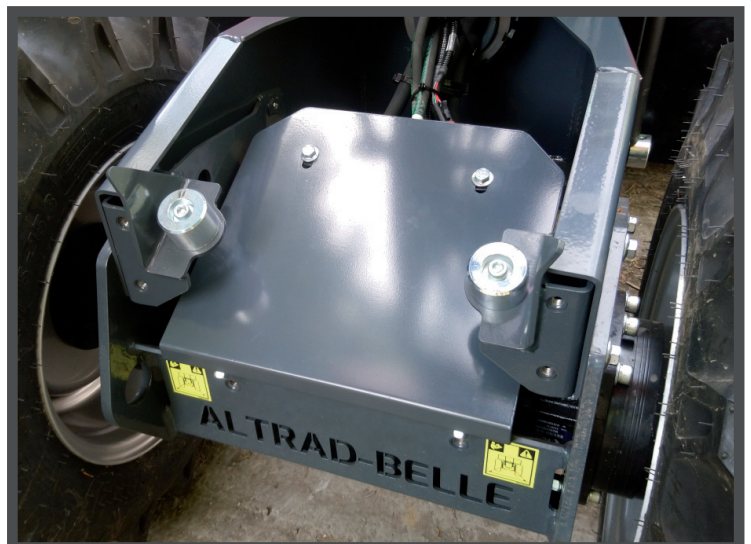

ROBUST STEEL, FRONT MATERIAL INGRESS GUARD PREVENTS DAMAGE TO HYDRAULIC CIRCUIT

DX 1000 1-TONNE HI-TIP DUMPER

Part NumberDX10HYSA

PERFORMANCE

Payload (kg) 1000
Unladen Weight (kg) 1363
Tipping Type Front Tip - High
Turning Circle of Skip (mm) 2637
Turning Circle of Tyres (mm) 2524
Steering Angle (°) 39.7
Body Oscillation Angle (°) 15

CAPACITIES

Skip - Water (Ltr) 280
Skip - Struck (Ltr) 400
Skip - Heaped (Ltr) 500
Fuel Tank (Ltr) 35
Hydraulic Oil Tank (Ltr) 18

ENGINE

Engine Model Yanmar 3TNV76
Type Diesel
No. of Cylinders 3
Gross Power (Hp/kW) 21.4 / 15.9
Displacement cc (cc) 1116
Max. Torque (Nm) 66.4

HYDRAULIC SYSTEM

Pump Type Gear Pump
Flow Rate (l/min) 30
Operating Pressure (bar/PSI) 140
Steering System Hydraulic

BRAKING SYSTEM

Working Brake Hydrostatic Dynamic Breaking
Parking Brake Failsafe Automatic

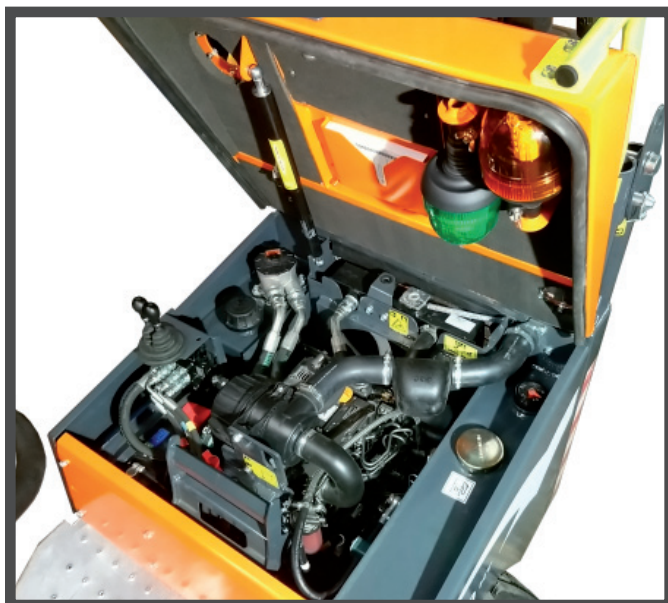

GOOD ACCESS TO KEY FEATURES WITH SELF-LOCKING GAS STRUT AND PROVEN YANMAR 3TNV76 DIESEL ENGINE

TRANSMISSION / DRIVE

Transmission Type Hydrostatic Pump to 4 radial piston Hydraulic Motors
Tyre Size 255 / 75 -15.3
Drive Hydrostatic
Max. Travel Speed (kph) 12 (Unladen)
Max. Gradient 25% (4:1)

ENVIRONMENTAL

- Sound Pressure (LpAd) 84
Sound Power Level (LWAd) 101
Noise Emission (to ISO 4871)

ELECTRICAL SYSTEM

System Voltage (V) 12
Battery Capacity (Ah) 44
Alternator Output (A) 40

STANDARD EQUIPMENT

Folding ROPS Frame ✓
Reversing Alarm ✓
Flashing Orange Beacon ✓
Hourmeter ✓
Seat Belt (Hi-Viz Orange) ✓
Adjustable Seat ✓
Heavy Duty Articulation Lock ✓
Wide Tyres ✓



ERGONOMIC OPERATOR STATION WITH EASY-TO-REACH CONTROLS, LEADING BRAND COMFORT SEAT AND GOOD ALL-ROUND VISIBILITY

STATIC DIMENSIONS*

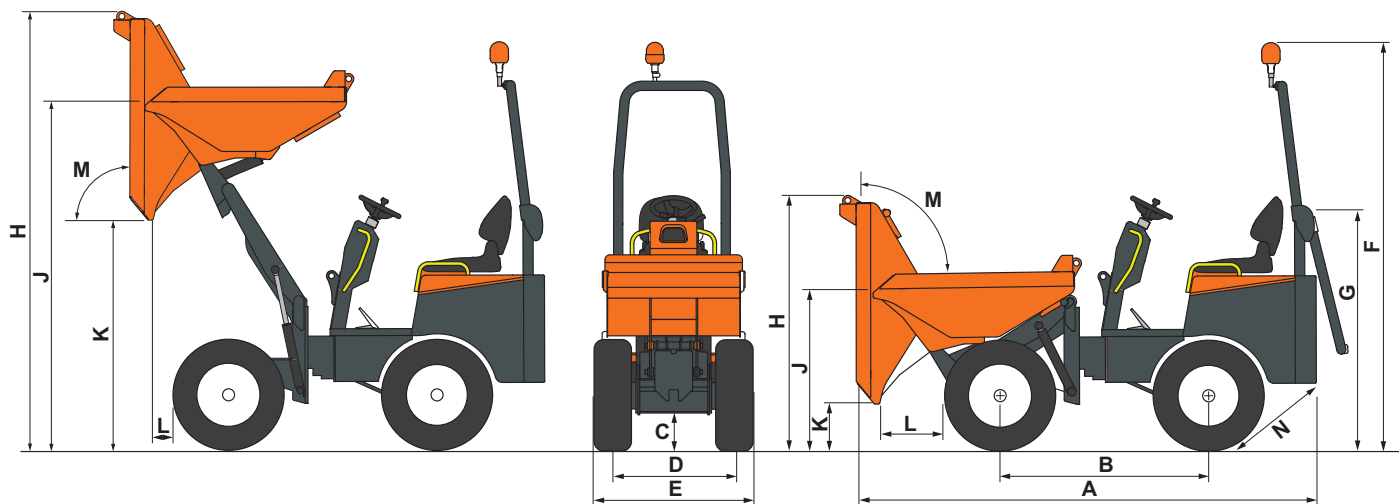

A - Overall Length.....	(mm)	3190
B - Wheel base	(mm)	1440
C - Minimum ground clearance	(mm)	250
D - Track width.....	(mm)	850
E - Width over tyres.....	(mm)	1100
F - Height to top of ROPS (raised, with/without beacons)	(mm)	2545 / 2800
G - Height to top of ROPS (folded)	(mm)	1630
H - Dump Height (untipped/tipped)	(mm)	1820 / 2960
J - Height to front lip of dumper body (untipped, lowered/raised)	(mm)	1110 / 2270
K - Height to front lip of dumper body (tipped, lowered/raised)	(mm)	400 / 1540
L - Discharge distance front (lowered/raised).....	(mm)	520 / 380
M - Dumper body tip angle	(°)	81
N - Departure angle	(°)	38

OPTIONS

Option Ready

- Green Beacon ready - fitted with seat belt sensor & main harness is ready to take Green Beacon option.
- Twin Beacon and work light approved ROPS structure.
- Fully loaded chassis harness - ready for options to be plugged in and used.
- Option ready console - ready for options to be plugged in and used.
- Customer colour options giving excellent brand awareness.

Options Available

Work Lights x 2	OPD/20/DIO
Work Lights x 4	OPD/21/DIO
Green Beacon	OPD/22/DIO



GREEN BEACON OPTION WITH LOCKABLE UNDER-CANOPY STORAGE



BELLE
LIGHT
CONSTRUCTION
EQUIPMENT

ALTRAD BELLE
Sheen, Nr. Buxton, Derbyshire, SK17 0EU, GB
Tel. +44 (0)1298 84606 - Fax +44 (0)1298 84722 - Email: sales@altrad-belle.com
www.Altrad-Belle.com
www.ALTRAD-Belle247.com